

# INSTALLATION INSTRUCTIONS



THIS PRODUCT MUST BE INSTALLED IN ACCORDANCE WITH THE APPLICABLE INSTALLATION CODE BY A PERSON FAMILIAR WITH THE CONSTRUCTION AND OPERATION OF THE PRODUCT AND THE HAZARDS INVOLVED.
CE PRODUIT DOIT ETRE INSTALLE SELON LE CODE D'INSTALLATION PERTINENT, PAR UNE PERSONNE QUI CONNAIT BIEN LE PRODUIT ET SON FONCTIONNEMENT AINSI QUE LES RISQUES INHERENTS.
DISCONNECT POWER PRIOR TO ANY INSTALLATION.
DEBRANCHEZ LE COURANT AVANT TOUTE INSTALLATION.
CAP ALL WIRING CONNECTIONS WITH UL APPROVED WIRE CONNECTORS.
COUVRIR TOUTES LES CABLES AVE DES CONNECTIONS APPROUVEES (UL).
VERIFY SUPPLY VOLTAGE MEETS LUMINAIRE LABEL SPECIFICATIONS.
VERIFIEZ QUE LA TENSION SOIT COMPATIBLE AVEC LES CARACTERISTIQUES DU LUMINAIRE MARQUE SUR LETIQUETTE.
ALLOW FIXTURE TO COOL BEFORE TOUCHING HEATSINK OR LIGHT SOURCE.
LAISSEZ LE PROJECTEUR REFOIDIR AVANT DE TOUCHER LE RADIATEUR OU LA SOURCE DE LUMIERE.
DO NOT ATTEMPT TO OPEN OR MAKE REPAIRS INSIDE LUMINAIRE.
NE PAS TENTER DOUVRIRE OU DE FAIRE DES REPARATINS A L'INTERIEUR DU LUMINAIRE.
AVOID DIRECT VIEWING OF LIGHT SOURCE.
EVITEZ DE REGARDER DIRECTMENT LA SOURCE LUMINEUSE.
THIS PRODUCT MUST BE INSTALLED BY A QUALIFIED ELECTRICIAN.
CE PRODUIT DOIT ITRE INSTALLE PAR UN ELECTRICIEN QUALIFIE.
SUITABLE FOR DAMP LOCATION.
ADAOTE POUR DES ENDROITS HUMIDES.
MIN 105° C SUPPLY CONDUCTORS.
MIN 105° C ALIMENTATION CONDUCTEURS.



## PERIMETER SLIMBEAM

## PERIMETER BEAM

Note: All pictures shown are of Perimeter Beam

# INSTALLATION INSTRUCTIONS

## Mounting locations

Mounting locations (●) vary due to length. Views below show top of fixtures and their hole location. For recessed applications, we offer two types of options. A hole in the back of the extruded housing for mounting to structure and extruded wall mount bracket. Both mounting styles require the application of screws into the drywall bezel. Please see below of mounting locations as these vary based on length of the fixture.

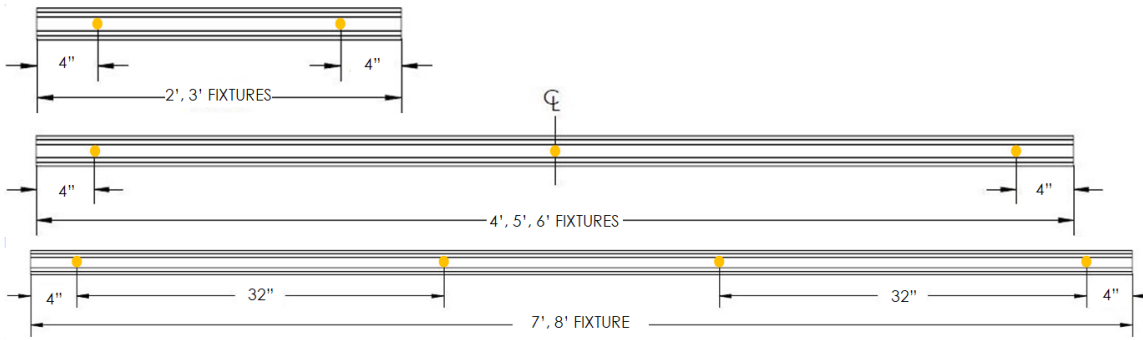

**Note:** Ordered fixture length is equal to the length of extrusion. The total fixture length is length of extrusion plus the endcaps.  
Example: 96" (ordered length) + .125" + .125" = 96.25" total length of assembled fixture.

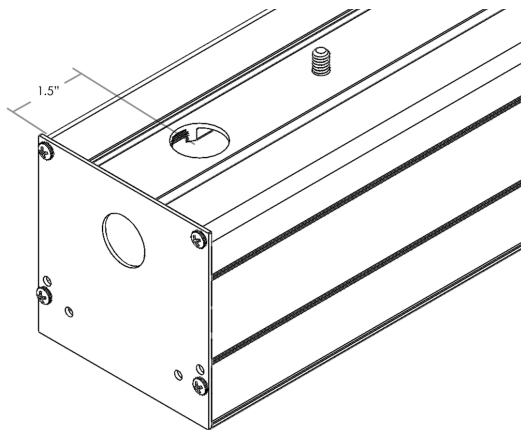

## Power location

The standard power location is hole out the top on the fixture. If a different configuration is needed to meet an aesthetic or placement requirement, please consult the factory.

## Driver Wiring diagram

Wiring configurations are dependent on the options chosen. Below are a few examples of our standard wiring that is used to power the fixture.

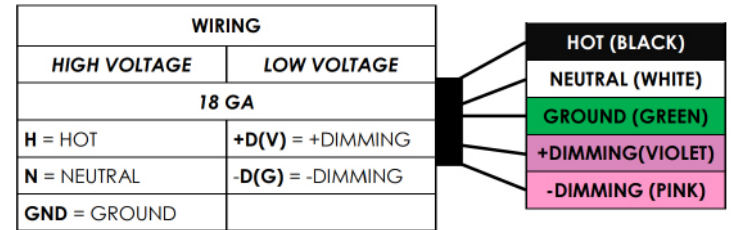

This wiring diagram is showing a standard set of wires for a basic fixture.

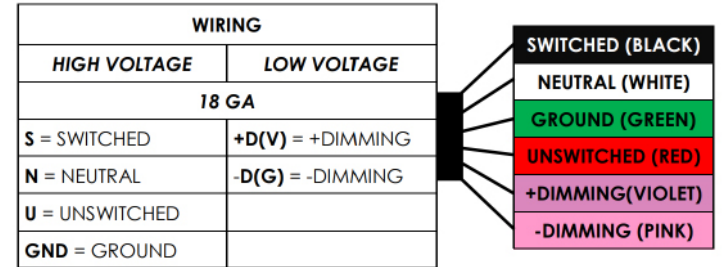

This wiring diagram is showing a set of wires for a fixture with a emergency battery.

**Note: DO NOT PUT LINE VOLTAGE INTO THE PINK AND VIOLET WIRES, THIS CAN DAMAGE THE DRIVER**

# INSTALLATION INSTRUCTIONS

## Perimeter Beam / Slim

### Fixed Fixture Installation

1. Remove fixture from packaging
2. Remove Extruded wall bracket from back housing.
3. Check rough-in dimensions in reference to the fixture assembly to verify the correct dimensions.
4. Install the extruded wall bracket using screws (provided by others) securing to structure. Holes to be drilled into the wall bracket by installer per onsite structure locations. Recommended to use a laser to strike a line across the wall to ensure the installation is level. (see illustration below)
5. Feed line voltage into the back extrusion assembly (location provided on pg. 2).
6. Install back housing to extruded wall bracket using provided hardware.
7. Wire fixture using the provided wiring diagram (pg. 2)
- 7b. During site construction it is recommended that the installer have the cardboard insert installed in the back housing to ensure back housing doesn't get compressed (if required)
8. While the lighting assembly is suspended from tethers, attach low voltage from the output side of the driver.
9. Attach lighting assembly to the back extrusion assembly by inserting the assembly into the back housing until it snaps into place.
10. Reinstall lens into back housing. Trim to length using provided cutting jig. (if required)
11. Reconnect power to turn fixture on. Installation is now complete.

### Extruded Wall Bracket Detail

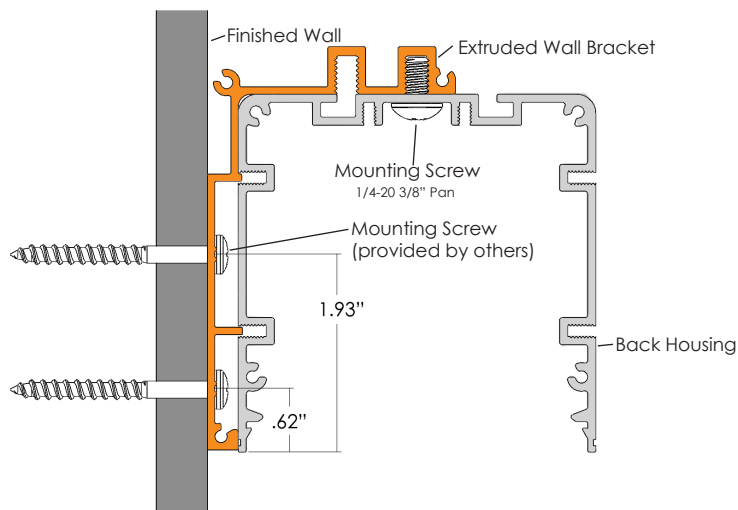

### Fixture Exploded View

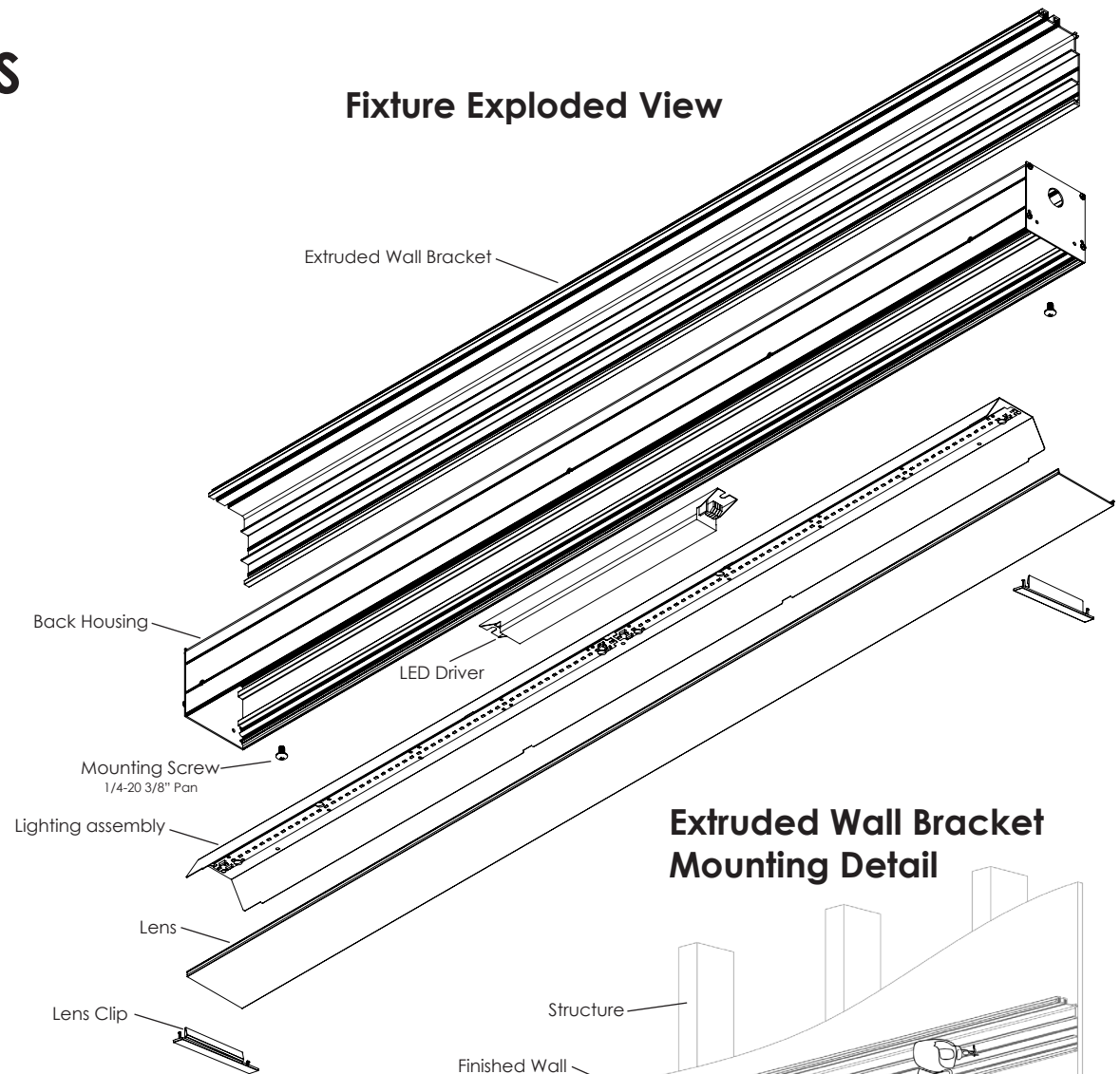

### Extruded Wall Bracket Mounting Detail

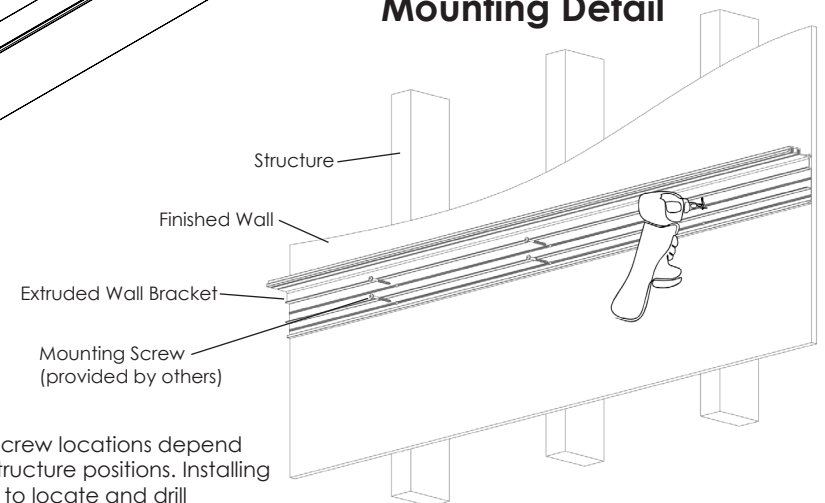

Mounting screw locations depend on onsite structure positions. Installing contractor to locate and drill mounting holes. Show without ceiling structure or drywall

# INSTALLATION INSTRUCTIONS

## Perimeter Beam / Slim

### Field Fit Individual Fixture Installation

1. Remove fixture from packaging
2. Remove Extruded wall bracket from back housing.
3. Check rough-in dimensions in reference to the fixture assembly to verify the correct dimensions. Field Fit section is built into the overall length of the end fixture. The end length will be either (FF3)3in or (FF6)6in over ordered length. (see wall to wall detail)
4. Install the extruded wall bracket using screws (provided by others) securing to structure. Holes to be drilled into the wall bracket by installer per onsite structure locations. Recommended to use a laser to strike a line across the wall to ensure the installation is level. (see illustration on pg. 3)
5. Measure distance wall to wall. Cut extruded wall bracket to fit.
6. Remove endcap from back housing. Cut back housing to match wall bracket. reinstall endcap to cut side of the back housing.
7. Feed line voltage into the back extrusion assembly (location provided on pg. 2).
8. Install back housing to extruded wall bracket using provided hardware.
9. Wire fixture using the provided wiring diagram (pg. 2)
- 9b. During site construction it is recommended that the installer have the cardboard insert installed in the back housing to ensure back housing doesn't get compressed (if required)
10. While the lighting assembly is suspended from tethers, attach low voltage from the output side of the driver.
11. Attach lighting assembly to the back extrusion assembly by inserting the assembly into the back housing until it snaps into place. Adjust sliding LED to fill gap at end of the fixture. It is OK for the sliding LED to cover part of the Lighting assembly.
12. Reinstall lens into back housing. Trim to length using provided cutting jig. (if required)
13. Reconnect power to turn fixture on. Installation is now complete.

### Fixture Exploded View

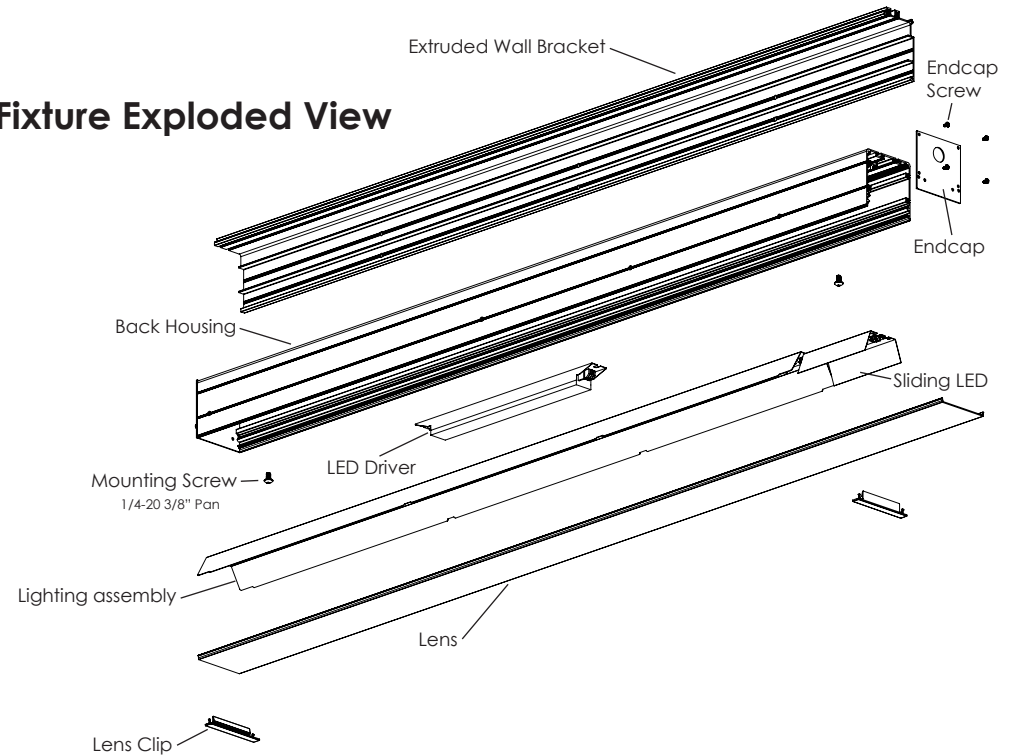

### Cutting Detail

- Step 1.**  
Remove the endcap before cutting the back extrusion.

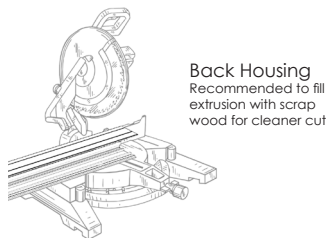
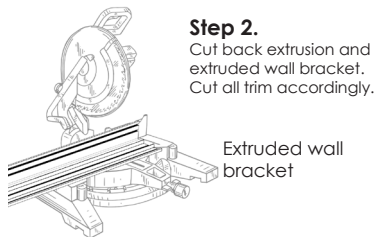
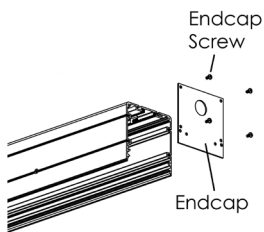

- Step 3.**  
Reinstall endcap. Reinstall telescoping lighting assembly and slide to the end. Filling the entire length with LEDs.

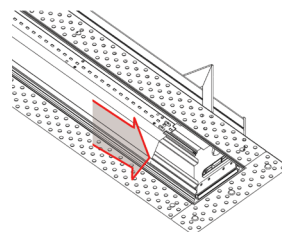

### Wall to Wall Detail

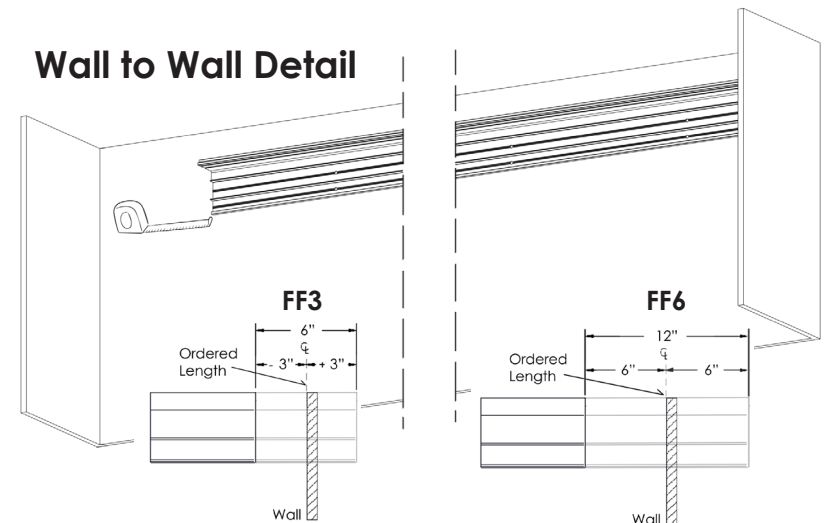

# INSTALLATION INSTRUCTIONS

## Perimeter Beam / Slim

### Adjustable Fixture Run Installation

1. Remove fixture from packaging
2. Remove Extruded wall bracket from back housing.
3. Check rough-in dimensions in reference to the fixture assembly to verify the correct dimensions. Field Fit section is built into the overall length of the end fixture. The end length will be either (FF3)3in or (FF6)6in over ordered length. (see wall to wall detail)
4. Measure distance wall to wall. Cut extruded wall bracket to fit.
5. Install the extruded wall bracket using screws (provided by others) securing to structure. Holes to be drilled into the wall bracket by installer per onsite structure locations. Recommended to use a laser to strike a line across the wall to ensure the installation is level. (see illustration on pg. 3)
6. Remove endcap from back housing. Cut back housing to match wall bracket. reinstall endcap to cut side of the back housing.
7. Install back housing to extruded wall bracket using provided hardware. Use latch and keeper to secure the extrusion housings together.
8. Feed line voltage into the back extrusion assembly (location provided on pg. 2). Splice to the wire harness.
9. Wire fixture using the provided wiring diagram (pg. 2)
10. While the lighting assembly is suspended from tethers, attach low voltage from the output side of the driver.
11. Attach lighting assembly to the back extrusion assembly by inserting the assembly into the back housing until it snaps into place. Adjust sliding LED to fill gap at end of the fixture. It is OK for the sliding LED to cover part of the Lighting assembly.
- 11b. During site construction it is recommended that the installer have the cardboard insert installed in the back housing to ensure back housing doesn't get compressed (if required)
12. Reinstall lens into back housing. Trim to length using provided cutting jig. (if required)
13. Reconnect power to turn fixture on. Installation is now complete.

### Wall to Wall Detail

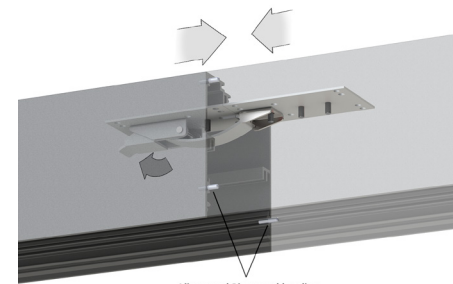
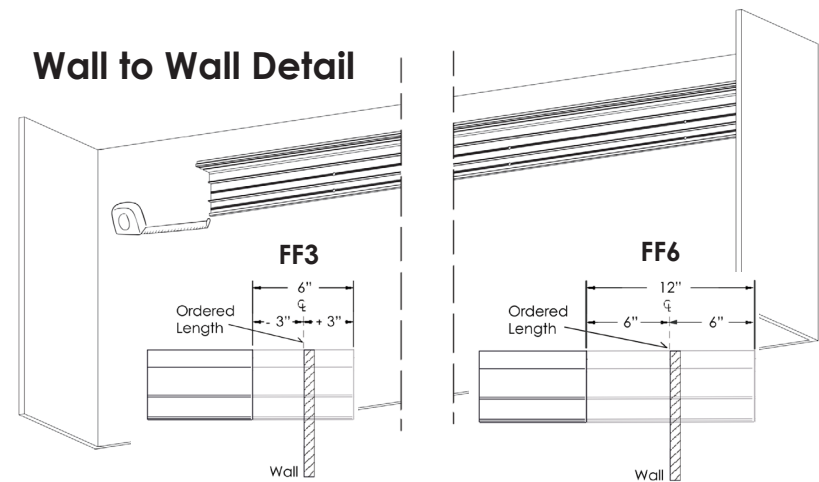

Alignment Pins used to align extrusions when joined

### Latch and Keeper Detail

### Wire Harness Detail

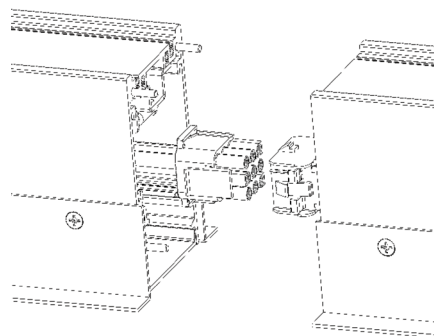

Wire harness has a quick disconnect located at each joint between fixtures



# INSTALLATION INSTRUCTIONS

## Perimeter Beam / Slim TBX Mounting Details

### Beam Mounting Widths

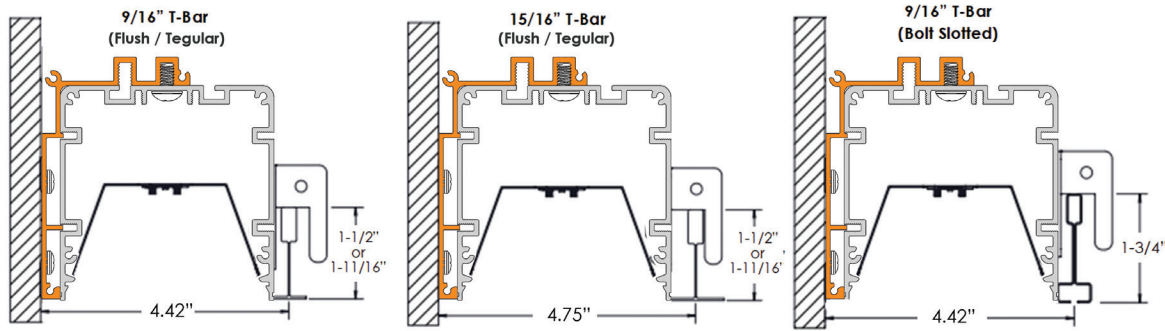

### T-Grid Universal Clip

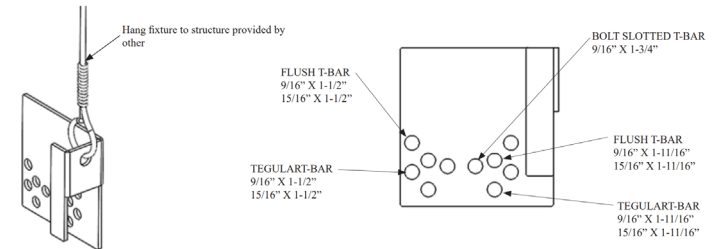

### Mounting Length end Detail

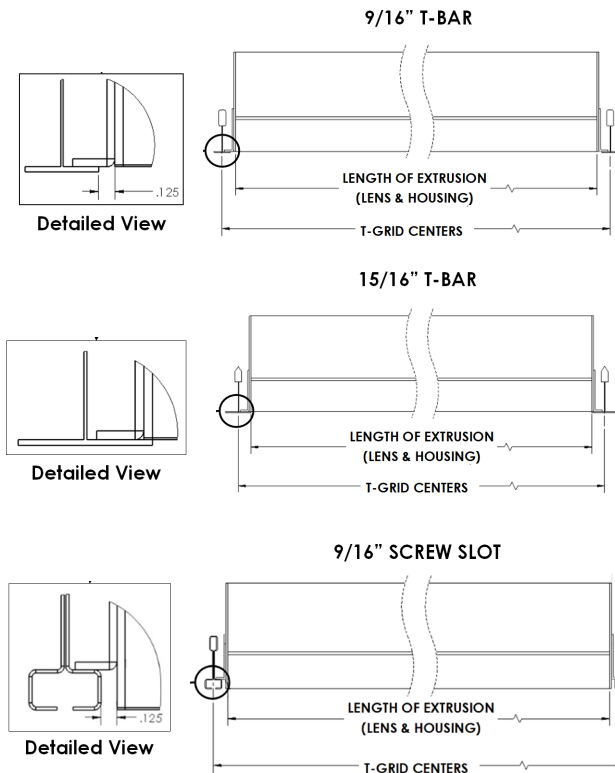

### T-Grid TBX Shielding Details

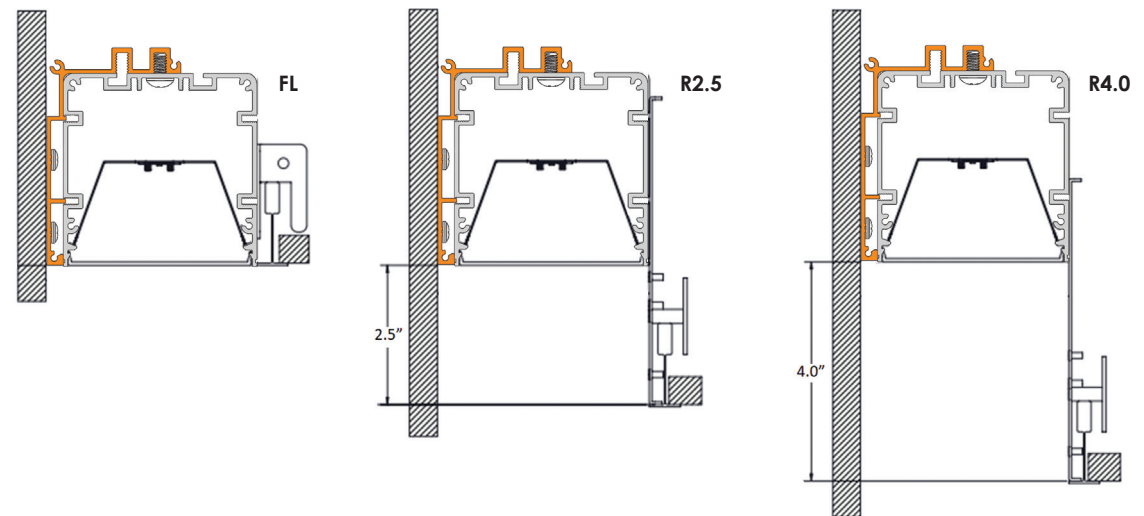

# INSTALLATION INSTRUCTIONS

## Perimeter Beam / Slim TBX Mounting Details

### Slim Mounting Widths

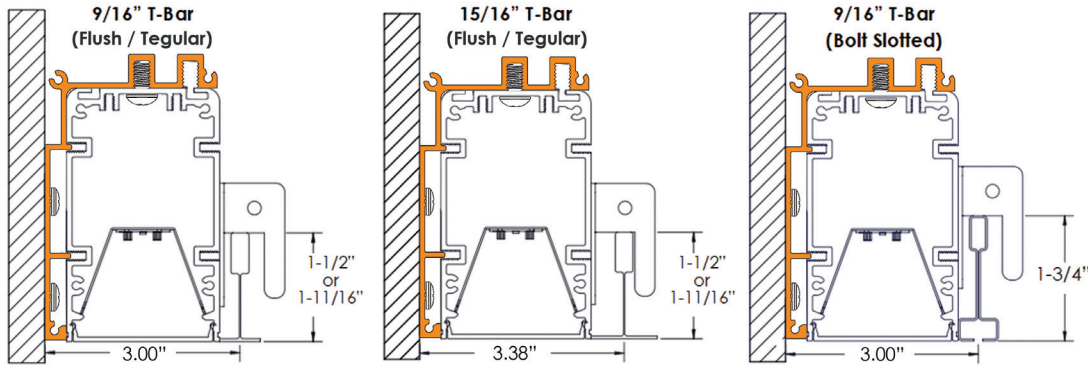

### T-Grid Universal Clip

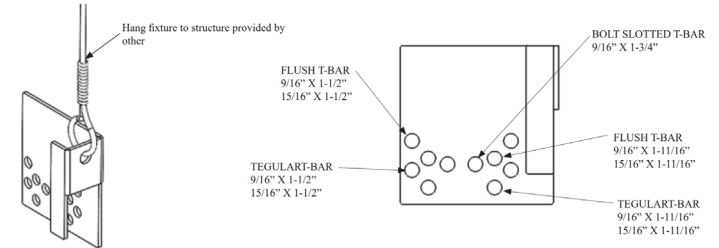

### Mounting Length end Detail

#### 9/16" T-BAR

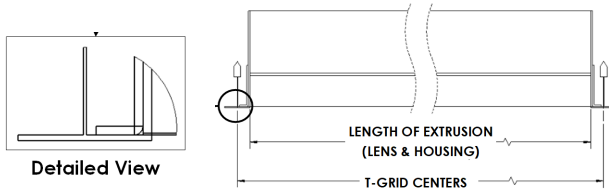
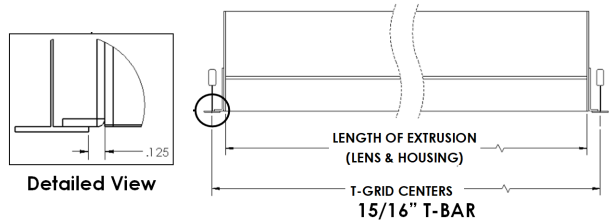

#### 9/16" SCREW SLOT

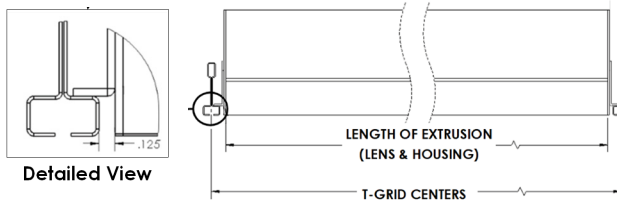

### T-Grid TBX Sheilding Details

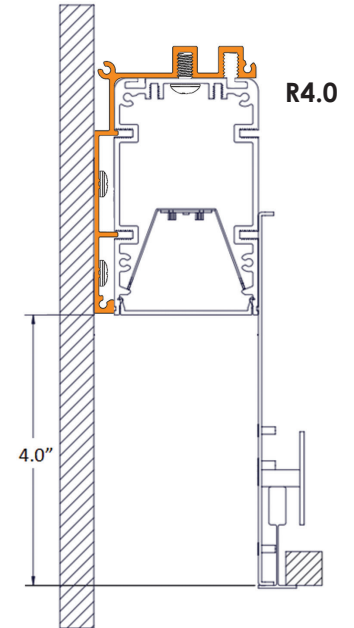
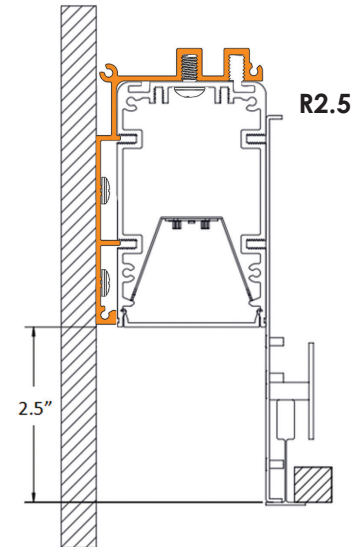
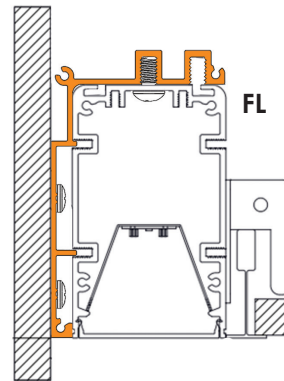

# INSTALLATION INSTRUCTIONS

## Perimeter Beam CB Mounting Details

### Cosmetic Bezel CB

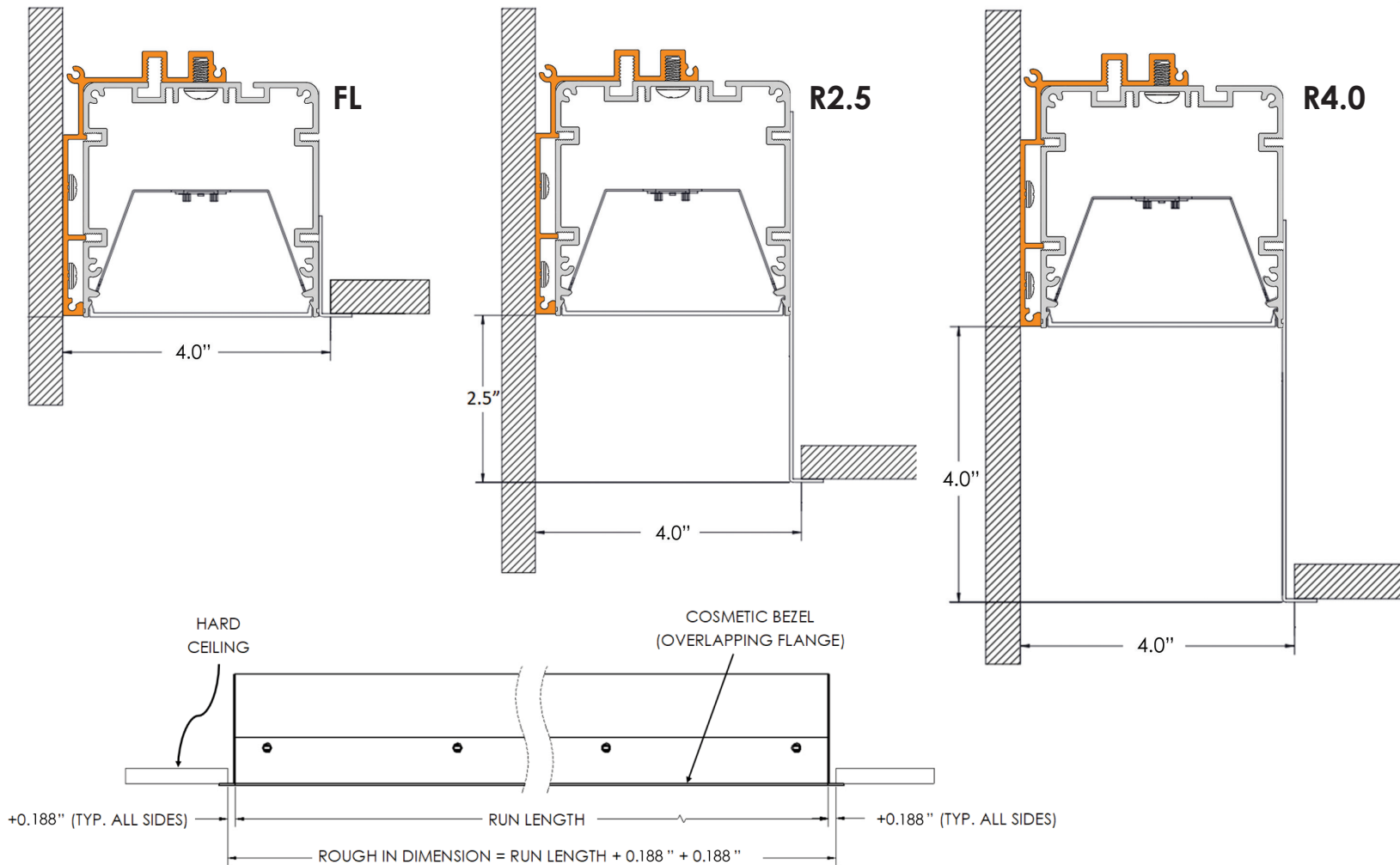

# INSTALLATION INSTRUCTIONS

## Perimeter Slim CB Mounting Details

### Cosmetic Bezel CB

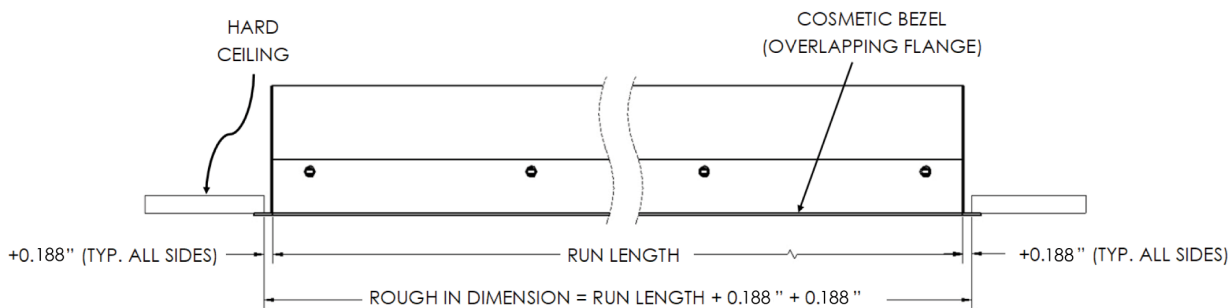
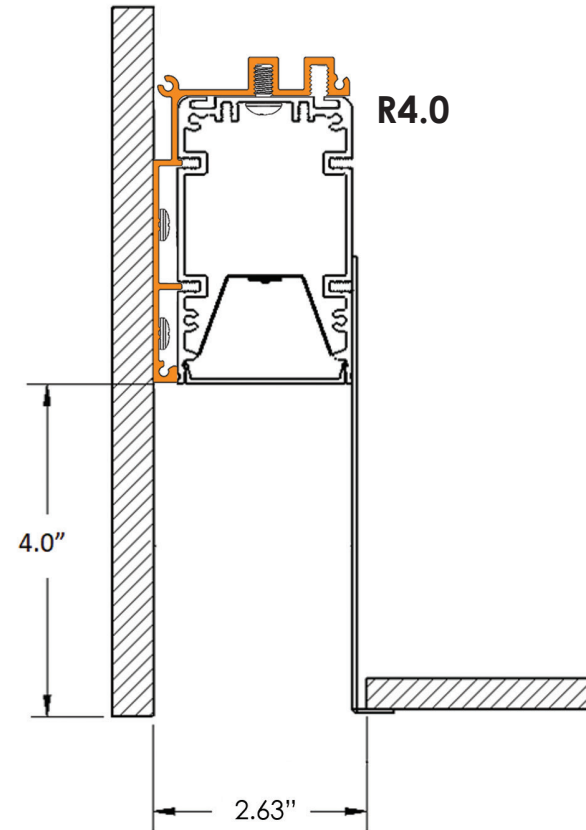
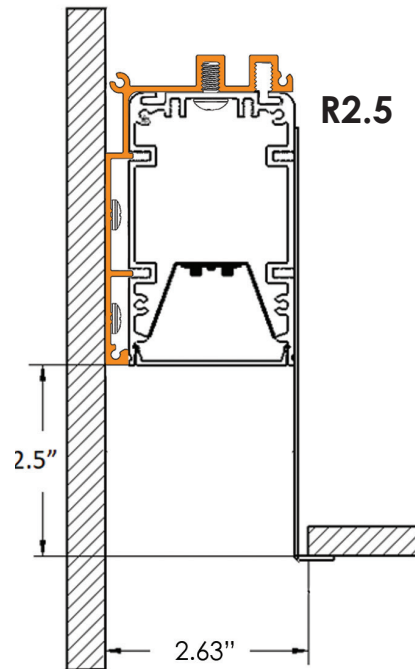
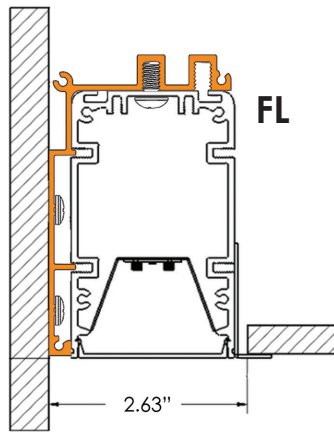

# INSTALLATION INSTRUCTIONS

## Perimeter Beam SF Mounting Details

### Spackle Flange SF

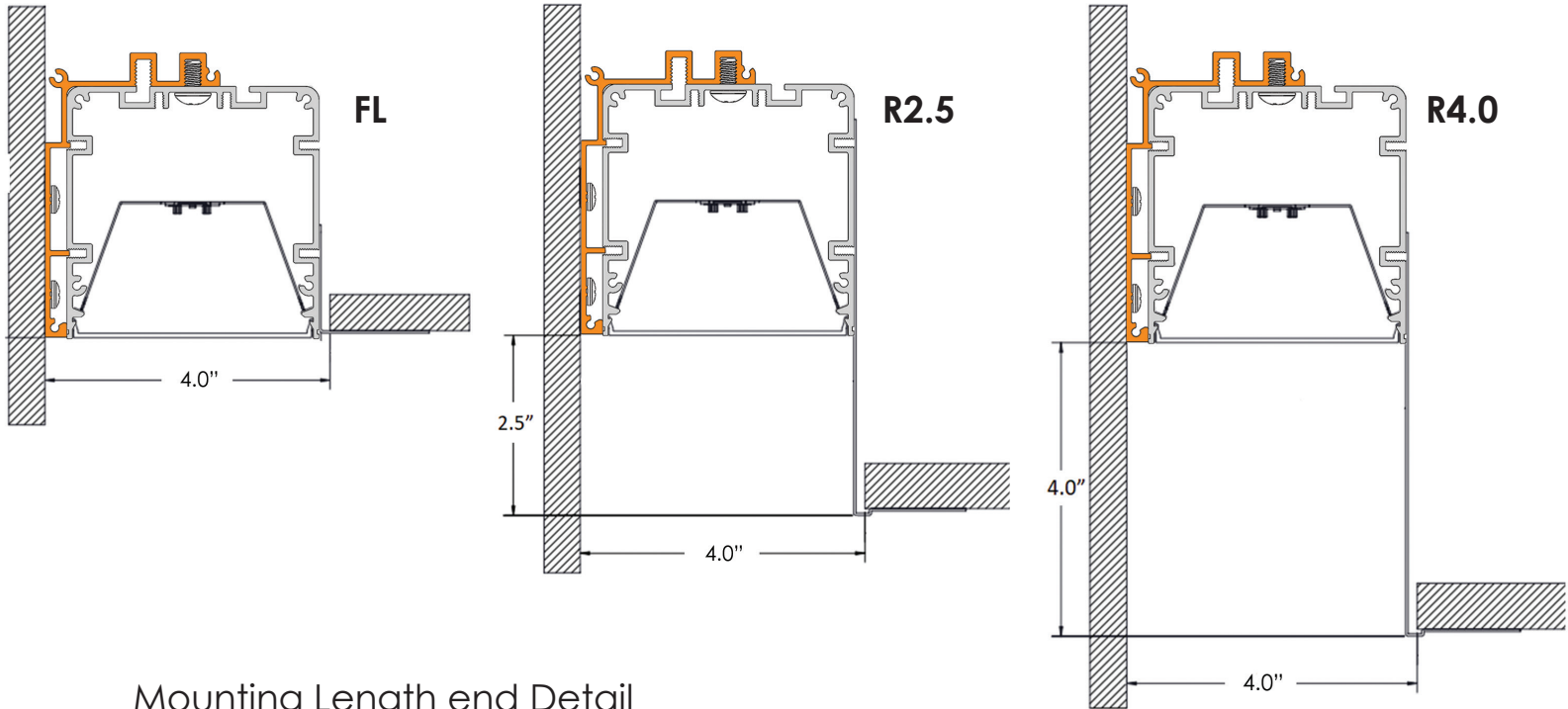

### Mounting Length end Detail

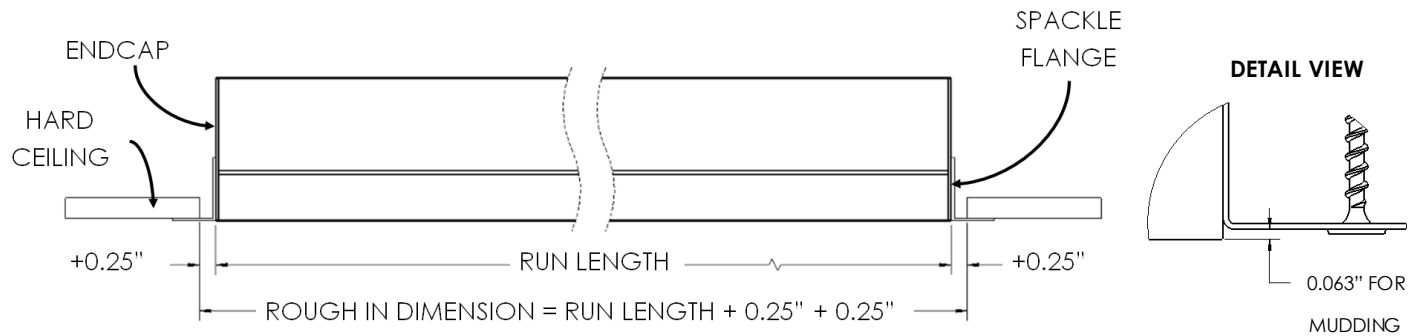

# INSTALLATION INSTRUCTIONS

## Perimeter Slim SF Mounting Details

### Spackle Flange SF

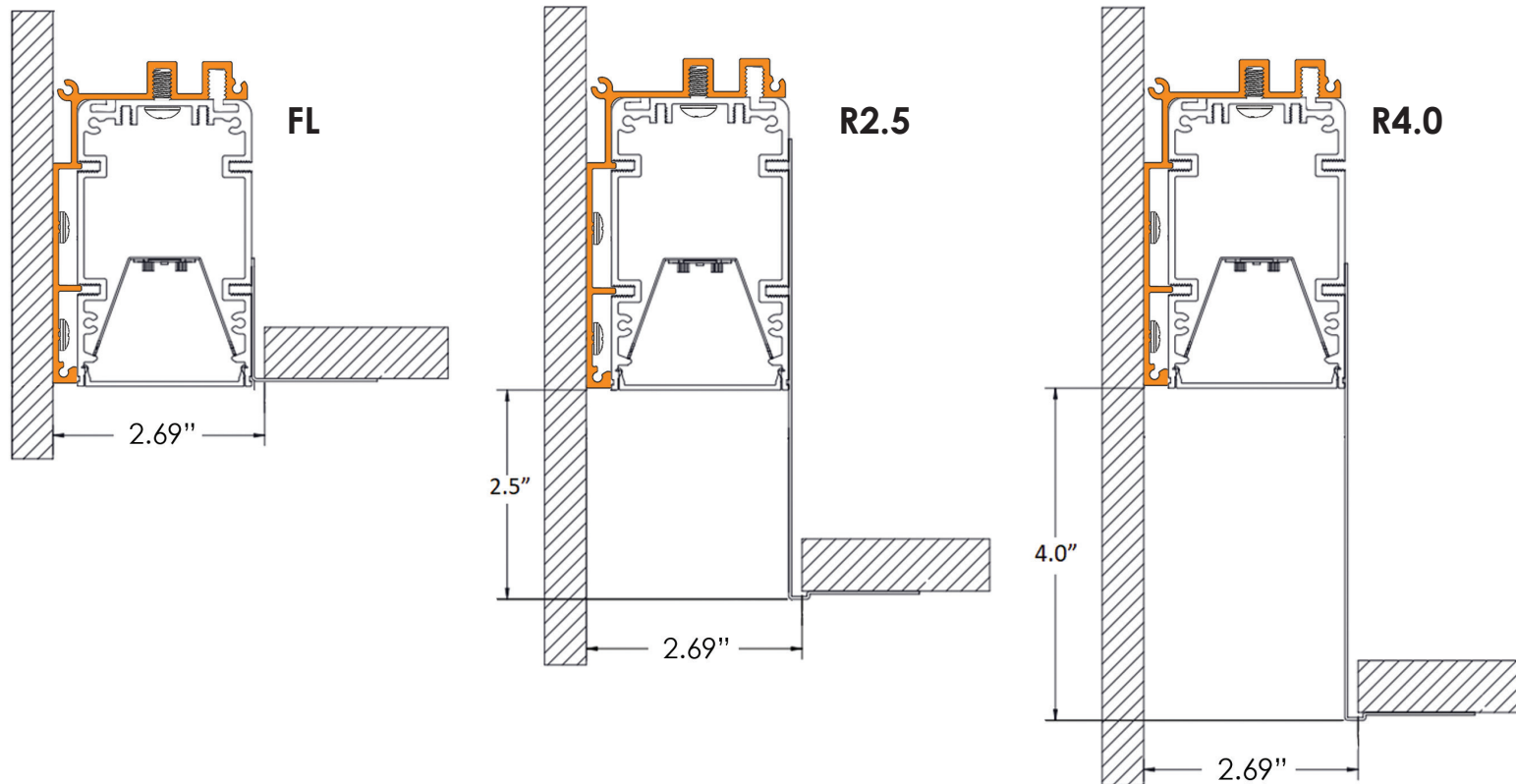

### Mounting Length end Detail

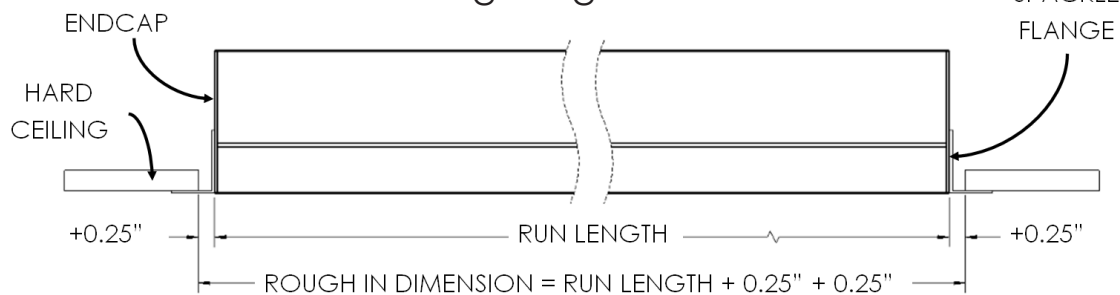

### DETAIL VIEW

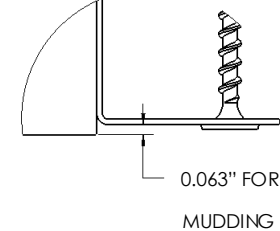

# INSTALLATION INSTRUCTIONS

## Perimeter Beam Trimless Mounting Details

Trimless TR

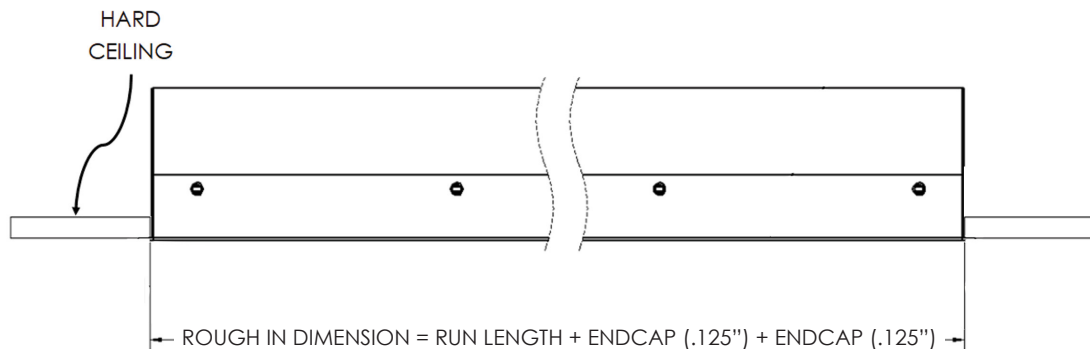
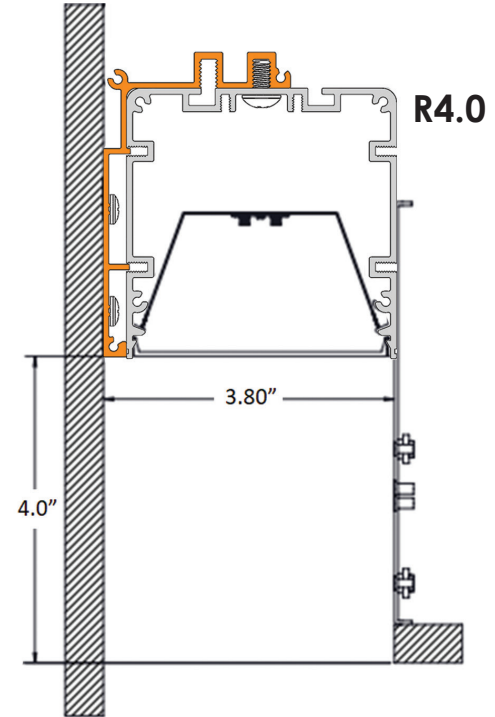
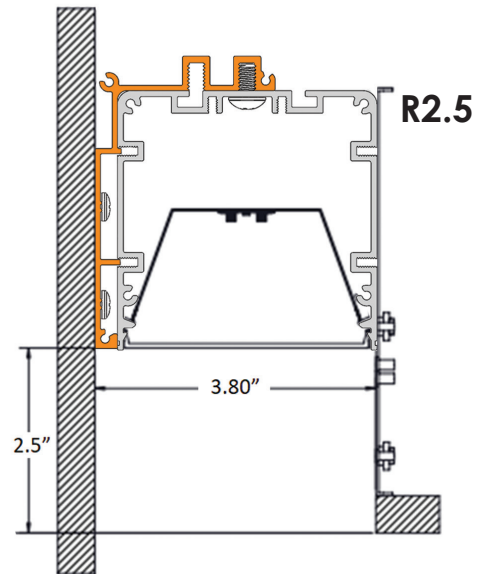
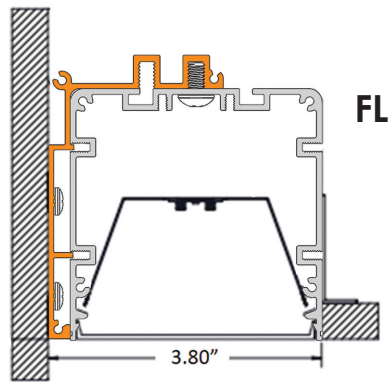

Note: Luminaires must be installed prior to ceiling drywall.

# INSTALLATION INSTRUCTIONS

## Perimeter Beam Trimless Mounting Details

### Trimless TR

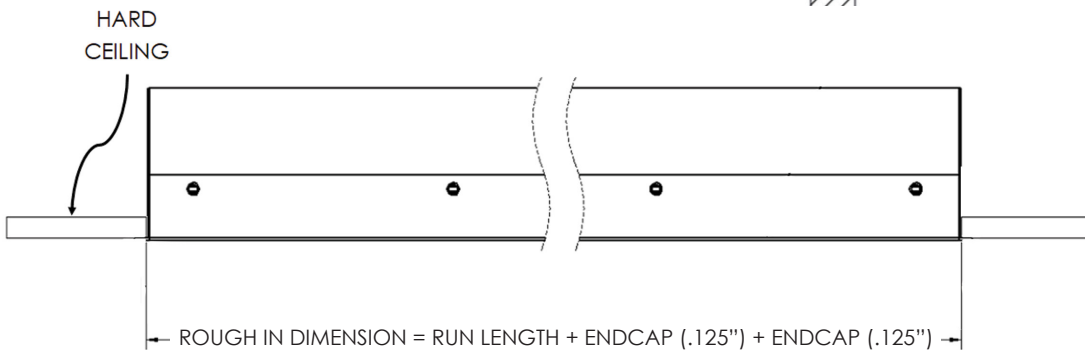
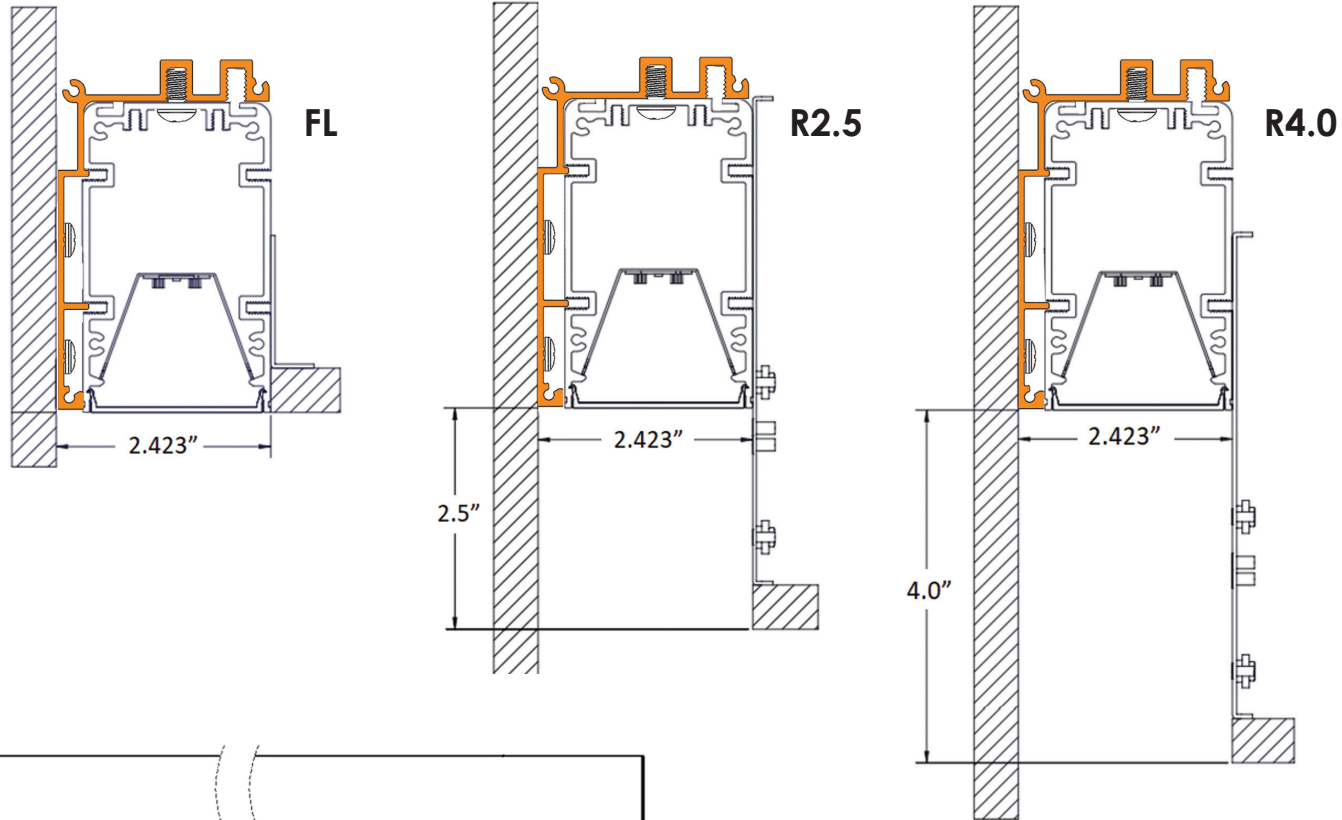

Note: Luminaires must be installed prior to ceiling drywall.

# INSTALLATION INSTRUCTIONS

## Continuous Lensing

The Recessed Beam, Recessed Slim, Surface Mount Beam, and Surface Mount Slim are all provided with a continuous rolled lens for any fixture length over 8'. This provides a superior lens aesthetic by eliminating any light leak throughout the entire length of the fixture. Our proprietary lens material retains no memory, so after the lens is uncoiled, it returns to a completely flat state, making installation effortless. Included with the lens, you will have received a lens cutting guide and a retractable razor. These will be in their own zip-loc bag, so please examine the packaging material of your fixture to ensure this does not get discarded. Please ensure you have all of these items available when beginning these instructions.

- 1: Start installing the lens into the fixture extrusion ensure that the edge of the lens lines up with the orange print on the inside of the endcap
- 2: Install the lens along the length of the extrusion assembly.
- 3: At the other end of the fixture put the lens over the endcap and mark where the edge of the orange print is. This marks the end of the lens. See illustration for details
- 4: Score the lens 3 times across with a sharp knife and then bend until it breaks at the score line using the lens scoring jig
- 5: install the lens and then install the lens retainer
- 6: Press the lens into place the entire length of the fixture ensuring lens is properly installed. **If the lens does not make full engagement over the entire length of the fixture it can lead to the lens falling out over time**

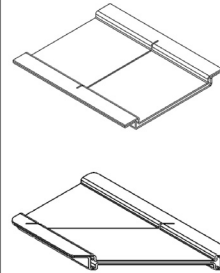
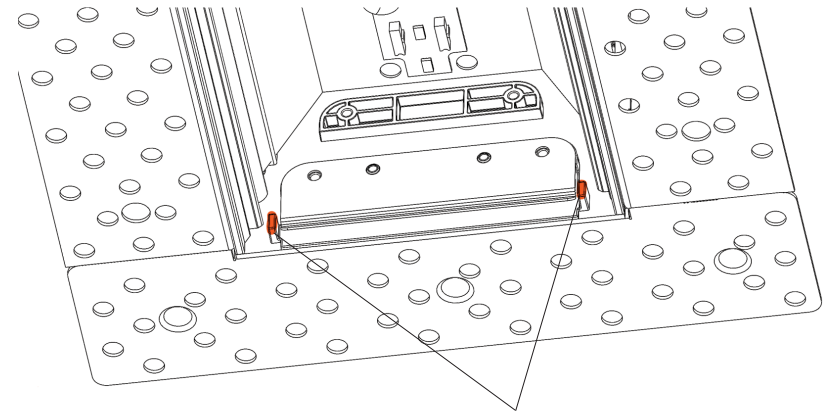

**Line up edge of lens with the orange stamp on the inside of the endcap**

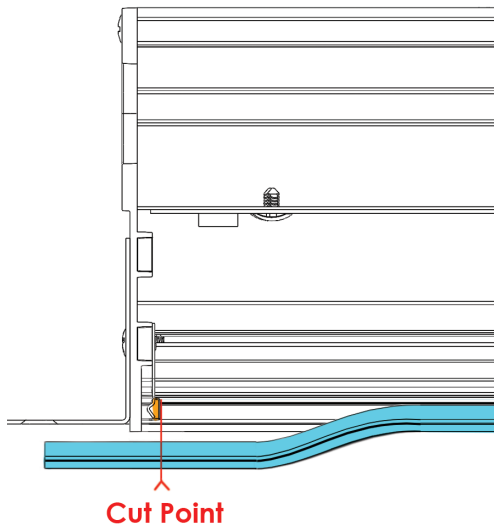

**Cut Point**

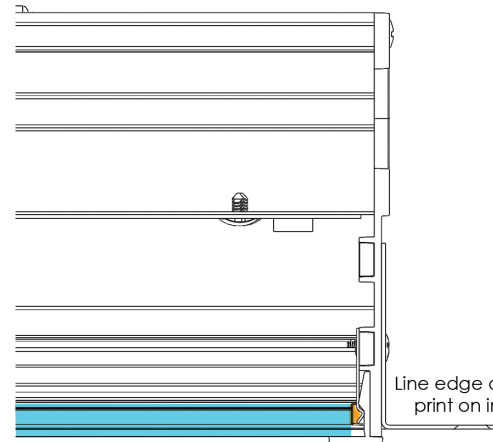

Line edge of lens with orange print on inside of endcap

**Ensure lens is behind the Lens Retainer**

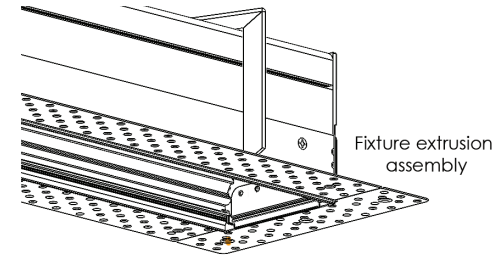

Fixture extrusion assembly

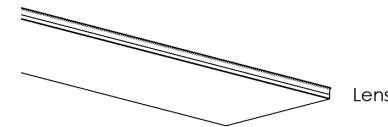

Lens



Lens Retainer